

APPLICATIONS: Converts 3832EC for face frame mounting. Front and rear brackets easily snap on the existing slide. * Rear bracket has a 2" (50.8) adjustment range. No tools needed. **This product covered by U.S. (5,904,412) and various foreign patents issued and/or pending.**

FACE FRAME CONVERSION KIT
Part Number 4180-0705-XE
 For Use With Slide Model **3832EC**
 Kit can be used with slide models: 3832CDO,
 3832CHDSC, 3832CSC, 3832C,
 3834CSC, 3834C, 3832CTR and 3832CHDTR

Installation Instructions

See 3832EC technical sheet for additional slide details.

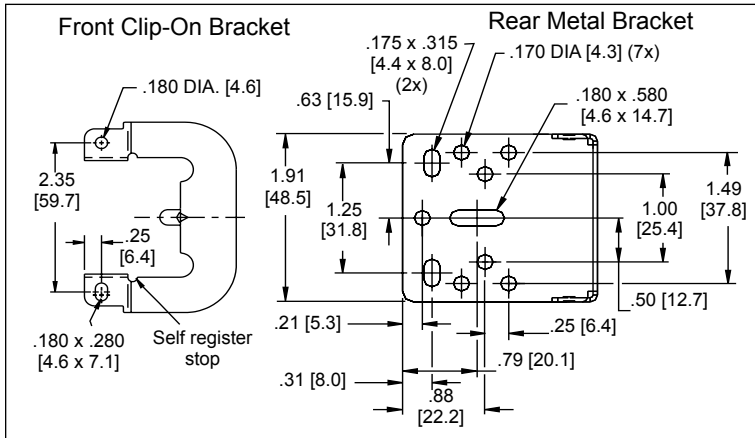

Attaching the Brackets

First, separate slide members by actuating the disconnect lever. Brackets are attached to cabinet (large) member.

Front Bracket

1. Position bracket on slide so tab engages second hole on slide. Bracket flanges will face inboard. See Figure 1.
2. Rotate bracket until it snaps in place, flush with front.

Rear Bracket

1. Push rear bracket onto the slide. See Figure 1.

Mount Slide to Cabinet

1. Secure a 3/4" x 2" vertical mounting strip to the rear wall or cabinet back for each slide.
2. Position the front bracket on the face frame opening and move it forward until the self-register stop hits the inside of the face frame opening. Install screw in the slotted mounting hole. Do not tighten screw completely at this time.
3. Extend the rear bracket until it contacts the rear vertical mounting strip. Check that both cabinet members are vertically and horizontally parallel. Mount the rear bracket using the two vertical slots. Make any necessary adjustment. See Figure 2.
4. Secure the rear bracket with a screw in round hole. Secure the front bracket with a screw in the round hole of the bracket. Tighten the original screw. See Figure 2.

Mount Slide to Drawer

1. Install drawer member through vertical slots.
2. Insert drawer member making sure ball bearing retainers are fully forward. Close drawer completely.
3. Adjust vertical position and install 2 more screws in round holes after free movement is achieved. See Figure 3.

Specifications

Front and rear face frame brackets: Cold rolled steel

RoHS compliant

NOTE: Specifications, materials, prices, terms, and delivery are subject to change without notice

For the most current technical information visit www.accuride.com

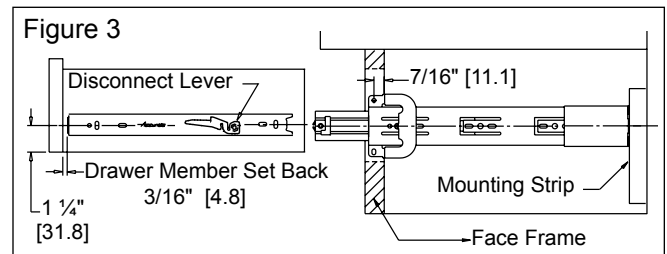
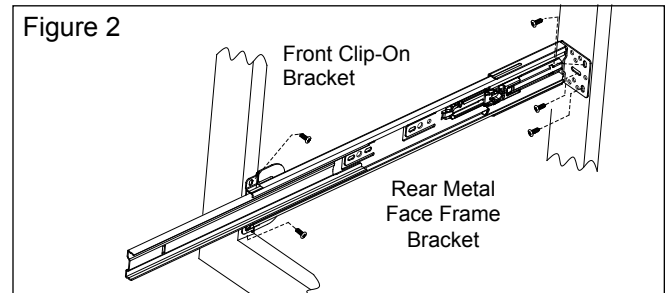
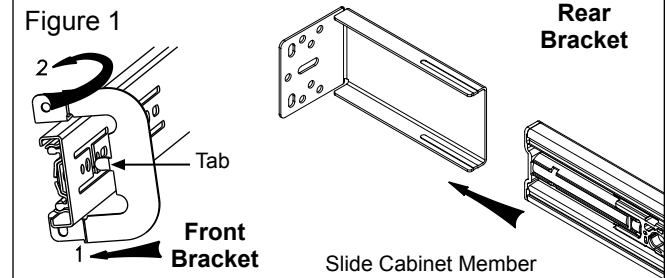

Ordering/Packaging Information

Order brackets in a **kit** or in **bulk**. Mounting screws are **not** included. Brackets are available in zinc finish only.

This face frame kit is compatible with models 3832CDO, 3832CHDSC, 3832CSC, 3832C, 3834CSC, 3834C, 3832CTR and 3832CHDTR.

Each kit contains two front and two rear brackets, and installation sheet. Order one kit per pair of slides ordered.

Bulk for model 3832EC order two front (P/N 4010-0516-CE) and two rear (P/N 4010-0668-CE) brackets per pair of slides.