



# INSTALLATION & OPERATION INSTRUCTIONS FOR PUSH PULL ROTATE™ KNOB LOCKSETS

999-00326E\_EN

FOR BRINKS HOME SECURITY™ INTERIOR NON-LOCKING PUSH PULL ROTATE™ KNOB LOCKSETS.

FITS DOORS 1-3/8" (35 mm) TO 1-3/4" (45 mm) THICK  
WORKS FOR BOTH IN-SWINGING AND OUT-SWINGING DOORS. SEE STEP 2.

QUESTIONS? CALL  
1-800-562-5625  
FOR HELP.

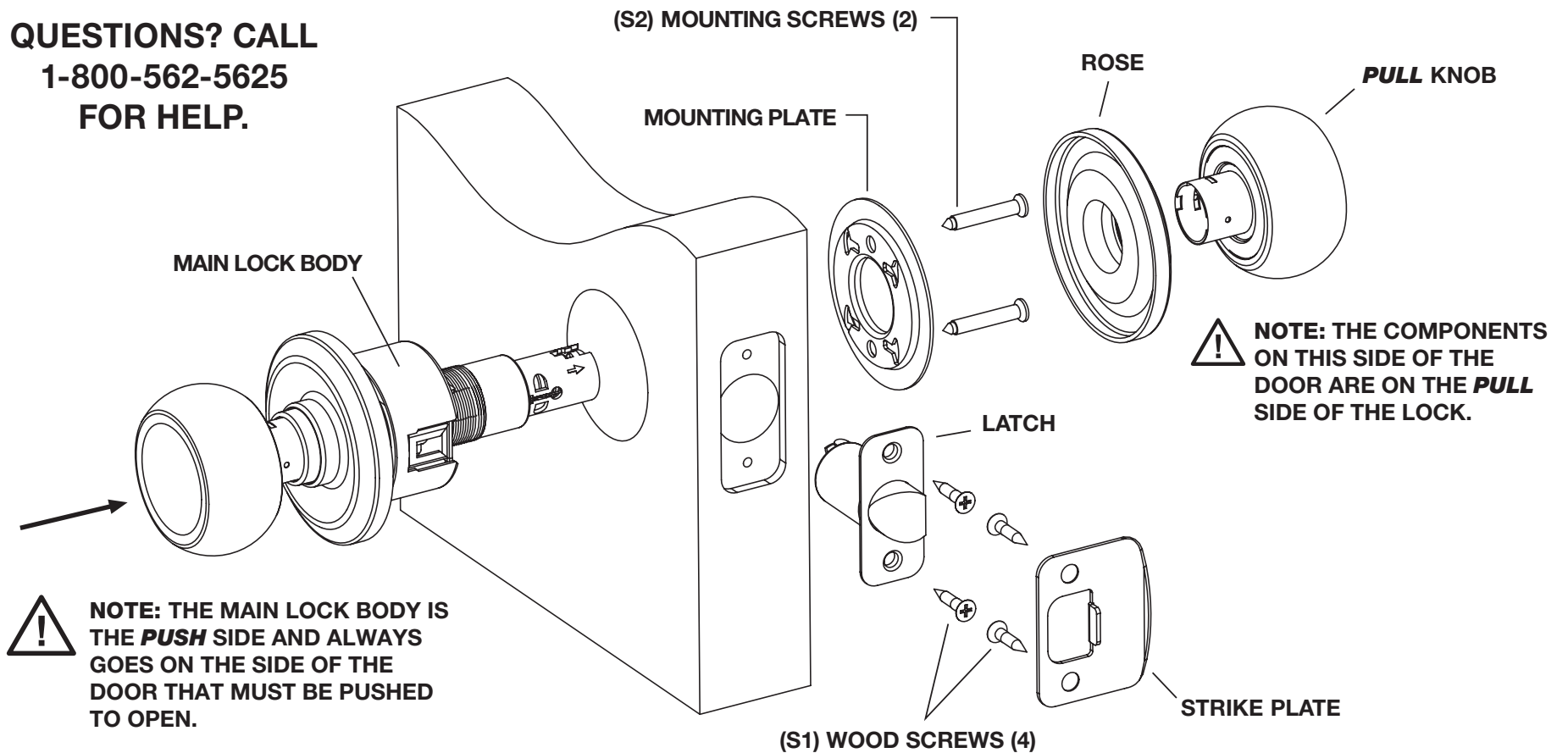

FOR NEW INSTALLATIONS, SEE INSTRUCTION 999-00321E\_EN. FOR REPLACEMENT INSTALLATIONS, PROCEED TO STEP 1.

**INSIDE KNOB REMOVAL: IF YOU PUT THE INSIDE KNOB ON THE CHASSIS BEFORE INSTALLING ON YOUR DOOR, FOLLOW THESE STEPS:**

- While holding the Outside Rose, Push the Outside Knob to expose the Knob Catch on the inside knob Spindle.
- Push the Removal Tool against the Knob Catch to depress it.
- Slide the knob off the Spindle.

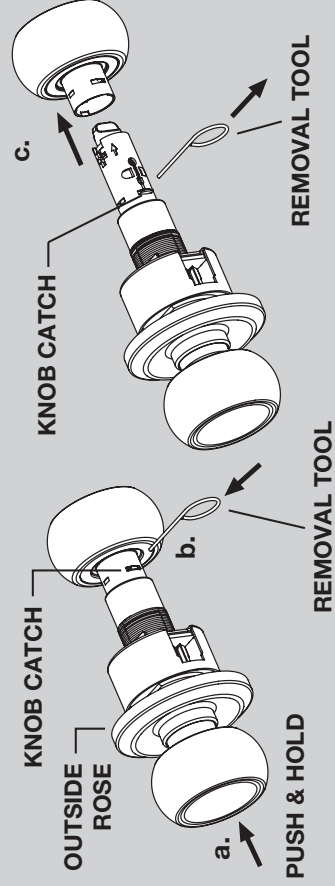

**FOR NEW INSTALLATIONS, SEE INSTRUCTION 999-00321E\_EN. FOR REPLACEMENT INSTALLATIONS, PROCEED TO STEP 1.**

**⚠ IMPORTANT!**

**STEP 1**

**Adjust For Door Thickness**

- Measure your door thickness. It should be 1-3/8" (35mm) or 1-3/4" (45mm), if in between these numbers, round to the nearest of those two thicknesses.
  - For 1-3/4" doors, rotate the Rose on the Main Lock Body counterclockwise (towards the slot in the spindle) until it stops. Then rotate back about a quarter turn.
  - For 1-3/8" doors, rotate the Rose on the Main Lock Body clockwise (towards the Retractor) until it stops. Then rotate back about a quarter turn.
- The purpose of this is to make sure that the Latch Tail will be approximately centered in the Retractor when installed.

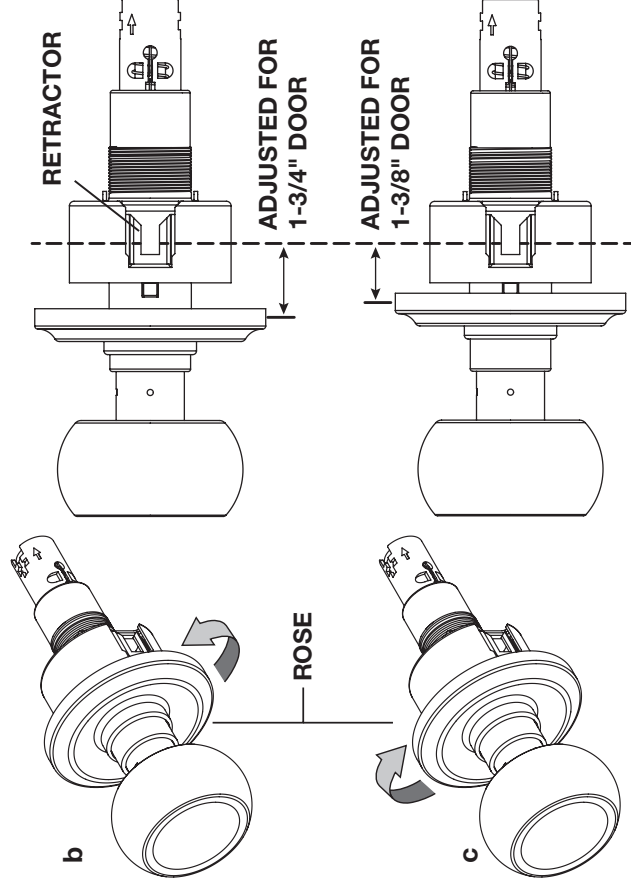

**STEP 2**

**Select Side of Door to Place Main Lock Body**

- The Interior Non-Locking Push-Pull-Rotate Knob can be installed on both In-Swinging Doors (doors that are pushed into the room to enter from outside) and Out-Swinging Doors (doors that are pulled open to enter a room from outside).
- The Main Lock Body is the PUSH mechanism. For In-Swinging Doors, it goes on the outside face of the door. For Out-Swinging Doors, it goes on the inside face of the door. The PULL Side Components always go on the side of the door on which the hinges are visible.
- After installation, you will PUSH the knob to enter a room with an In-Swinging Door, or PULL the knob to enter a room with an Out-Swinging Door.

**VIEW FROM OUTSIDE THE ROOM**

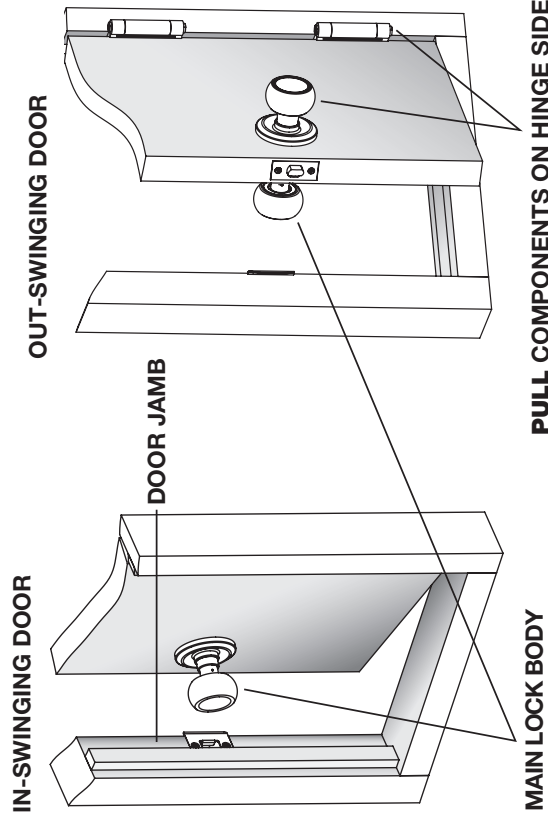

### STEP 3 Select Appropriate Latch

- a. Backset is the distance from the door edge to the center of the 2-1/8" (54mm) hole on the door face.
- b. Select the 2-3/8" (60mm) or 2-3/4" (70mm) latch based on the backset of your door. (Most residential doors have a 2-3/8" backset.)

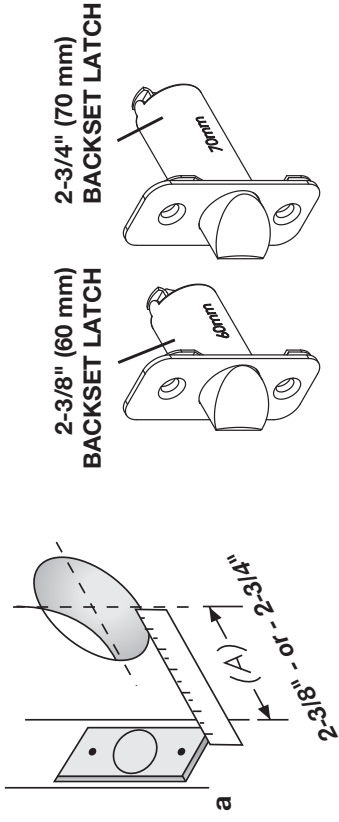

### STEP 4 Install Latch

- a. Insert the latch into the 1" (25.4 mm) hole in the door edge as shown. Be sure the sloping face of the latch bolt is facing towards the door jamb.
- b. Insert two (S1) Wood Screws in the faceplate holes and tighten.
- c. After installation, you should be able to see the Latch Prongs and Latch Tail(s) through the 2-1/8" bore in the door as shown. If not, review Step 3. Select Appropriate Latch.

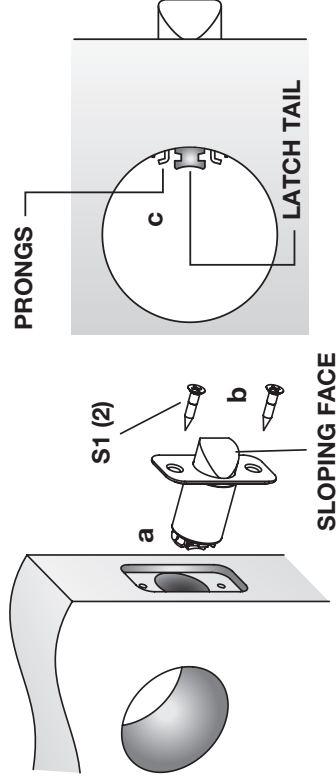

### STEP 5 Install the Main Lock Body

- a. Refer to Step 1 to determine on which side of the door the Main Lock Body will be installed.
- b. Note: The sloping face of the latch bolt always faces the door jamb and the Main Lock Body.
- c. Insert the Main Lock Body through the 2-1/8" (54mm) hole in the door.
- d. Look through the hole from the inside of the door to guide the Main Lock Body.
- e. Make sure that the Cylindrical Case engages with the Latch Prongs and the Retractor interlocks with the Latch Tail.
- f. Test by rotating the knob - the latch bolt should retract.

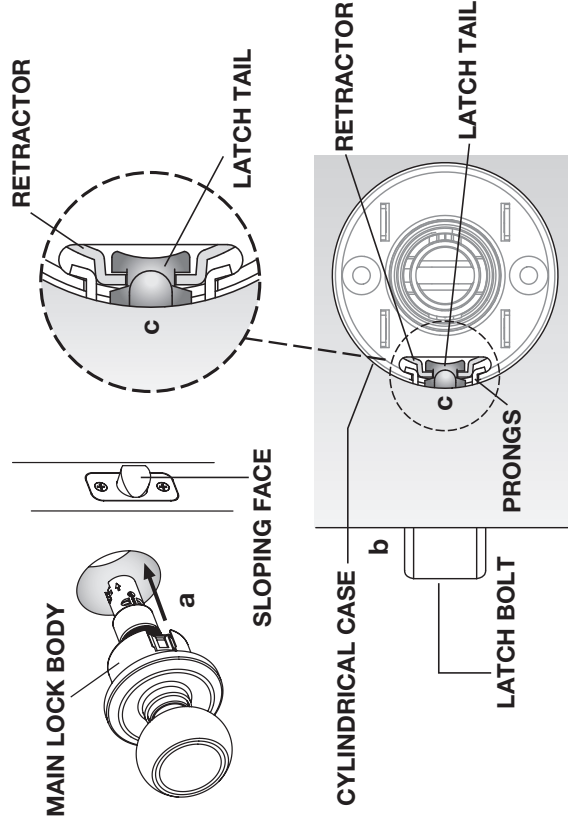

### STEP 6 Install the Mounting Plate & Rose

- a. Place the Mounting Plate over the Main Lock Body and against the Inside Door face with the mounting holes aligned vertically.
- b. Insert the two (S2) Mounting screws and engage the threaded holes in the Main Lock Body. Tighten firmly.
- c. Install the Inside Rose by engaging the thread on the Main Lock Body and rotating clockwise until it contacts the Inside Door face.

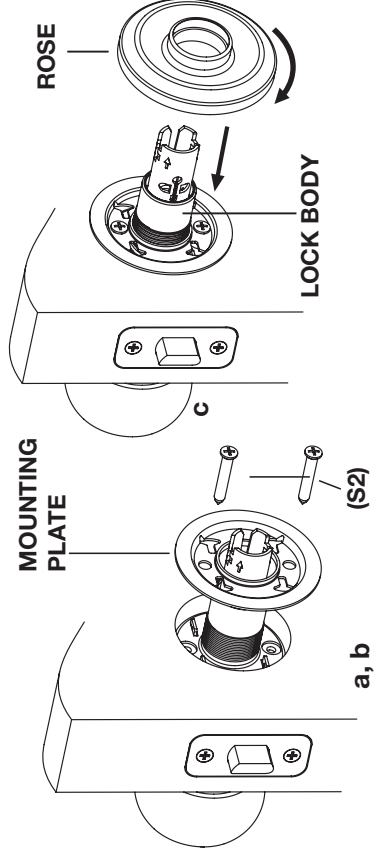

## STEP 7

### Install the Inside Knob

- Push and hold the Outside Knob to expose the Knob Catch.
- Align the hole in the Pull Knob with the Knob Catch on the spindle.
- Slide the knob on the spindle until it engages the Knob Catch and clicks into place. Pull on the Inside Knob to make sure it is secure.

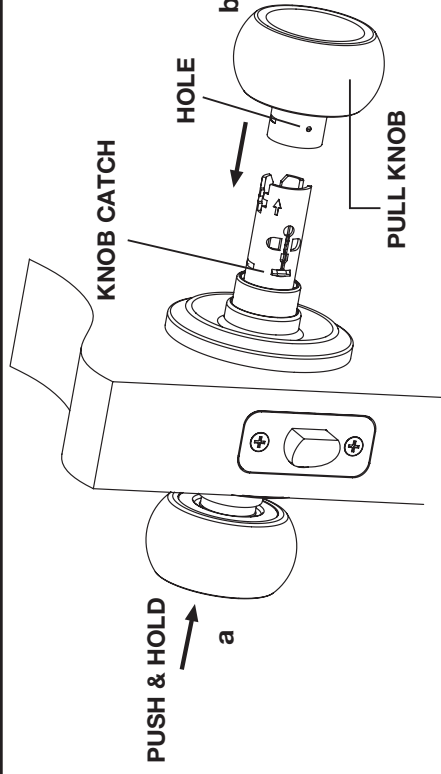

## STEP 8

### Install Strike Plate

- Secure the Strike Plate with two (S1) Wood Screws. Tighten firmly.
- It is important for Push-Pull-Rotate Locks for the Latch Bolt to move freely in and out of the Strike Plate.

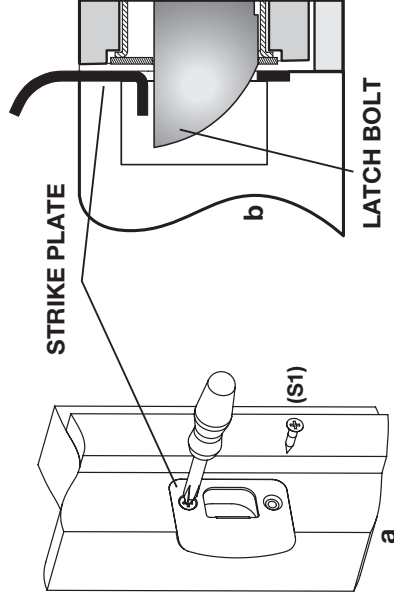

## STEP 9

### Operation & Troubleshooting

#### In-Swinging Doors

- To open the door from the outside, Push the knob or rotate the knob in either direction.
- To exit the room, Pull the knob or rotate the knob in either direction.

#### Out-Swinging Doors

- To open the door from the outside, Pull the knob or rotate the knob in either direction.
- To exit the room, Push the knob or rotate the knob in either direction.

#### Troubleshooting

- The Push and Pull functions work best when the latch bolt can move freely in and out of the Strike Plate.
- Weather stripping or a warped door can sometimes force the bolt against the Strike Plate. This will increase the force necessary to Push or Pull the knob. For best results, re-position the Strike Plate so there is no force against the bolt.

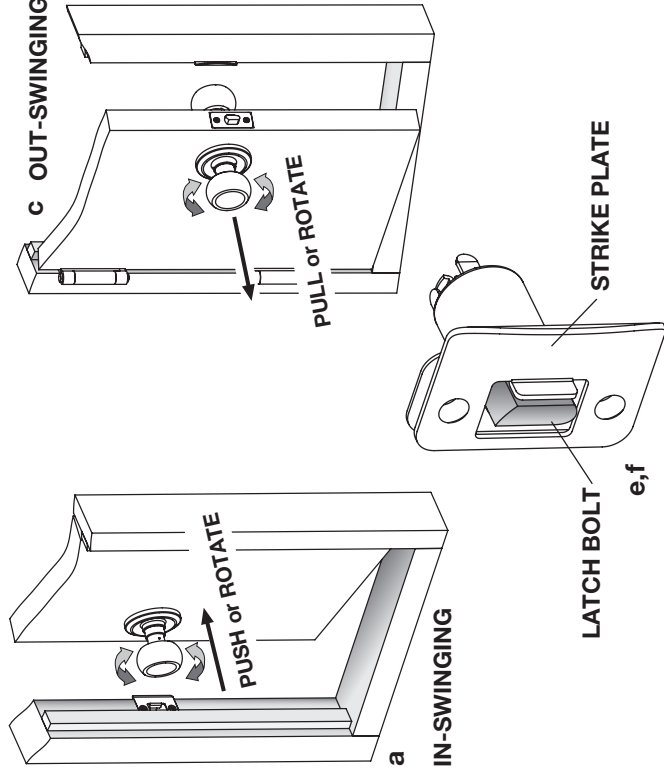

**FULL LIFETIME WARRANTY** - This product is fully warranted to be free of defects in material and workmanship for the life of the product. If a defect in material or workmanship occurs, call 800-562-5625 for instructions on how to have it replaced or repaired free of charge. This warranty is null and void if the product was used for purposes for which it was not designed, is abused, misused, modified or improperly installed, operated, maintained, and/or repaired. **NOT LIABLE FOR INCIDENTAL, INDIRECT, OR CONSEQUENTIAL DAMAGES.** Some states do not allow the exclusion or limitation of incidental or consequential damages, so the above limitation or exclusion may not apply to you. This warranty gives you specific rights, and you may also have other rights that vary from state to state.



Brink's trademark & copyright  
works are used with permission.

999-00326E\_EN\_REVA

Hampton Products International Corp.  
50 Icon, Foothill Ranch, CA 92610-3000 USA  
www.hamptonproducts.com 1-800-562-5625  
www.brinksppr.com  
©2015 Hampton Products International Corp.  
999-00326E\_EN\_REVA 02/15