

SECTION B-B
SCALE 1 : 4

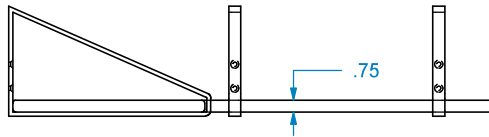
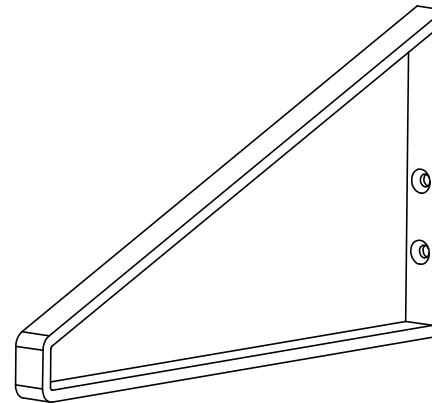
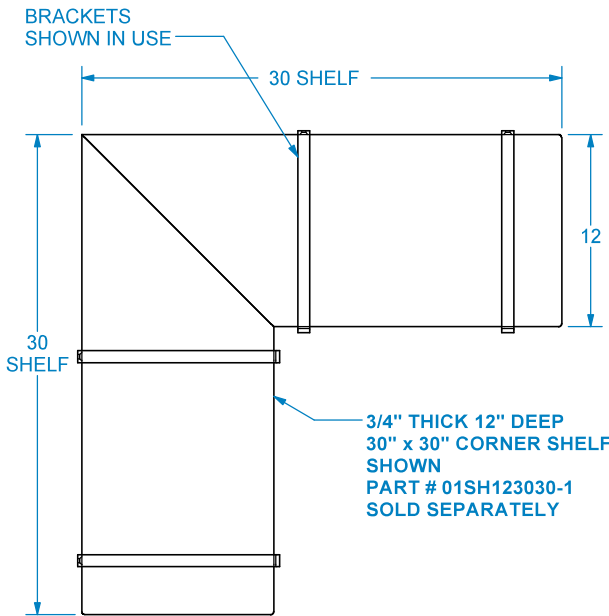

Designs of
distinction
by Brown Wood, Inc.
est. 1927

REVISION HISTORY		
REV	REV DATE	DESCRIPTION

TOLERANCES	
WIDTH	± .03125"
THICKNESS	± .03125"
LENGTH	± .0625"
ANGULAR	± x.x°
PROFILE	± x.xxx"
Use General Tolerances Unless Noted	

METAL FINISHES AVAILABLE	
(SN) SATIN NICKEL	(GR) GUN METAL GREY
(WR) WROUGHT IRON	(RS) RAW STEEL
(GL) GOLD	(SS) STAINLESS STEEL
NOTES: Do not scale. Use dimensions only. All dimensions are in inches unless noted	

TITLE: 12" MID CENTURY TRIANGLE BRACKET-	
NOMINAL SIZE .75" X 12.625" X 6.875"	
DWG #: 01651270-1	REV:
DATE: 6/23/2017	SCALE: 1:12