



206 Series Folding L-Brackets

HEAVY-DUTY

- Up to 880 lbs./pair*
- For 12" - 24" deep shelving
- Stationary brackets



Applications

Heavy-duty storage and work surface applications where limitations and/or flexibility in space is critical (Retail/grocery stores, warehouses, industrial, garages, maintenance storage, office/residential storage).

Load Rating:

- 12" Brackets: Up to 750 lbs./pair*
- 16" Brackets: Up to 880 lbs./pair*

Mounting: Wall

Material: Cold rolled steel

Finishes:

White (WH), Zinc (ZC): Long-lasting, corrosion resistant finishes

Features:

These sturdy folding L-brackets allow you to create a worksurface that can be quickly folded out of the way when no longer needed. The KV 206 bracket's convenient one-hand release mechanism makes the bracket easy-to-open, close, or adjust without the danger of getting hands caught in a folding crossbar.

- Brackets can be mounted to any type of wall
- Adjustable to 4 positions: 90°, 80°, 70°, and 0° (closed position)
- Dimensions:
12" (300mm): (11.81") deep x 200mm (7.87") high
16" (400mm): (15.75") deep x 270mm (10.63") high
Width:
12" (300mm): 15mm (0.59")
16" (400mm): 20mm (0.79")
- Durable zinc-coated steel construction with spring-loaded release lever
- Exceeds BHMA static load testing requirements
- Available from open stock

*Contact KV Customer Service for more information.



Zinc (ZC)



White (WH)

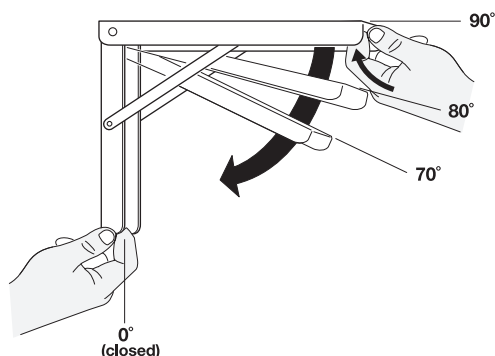

206 Series Brackets

Standard Pack (10/pack)			
	Size	White (WH)	Zinc (ZC)
12"	300mm	206 WH 12	206 ZC 12
16"	400mm	206 WH 16	206 ZC 16

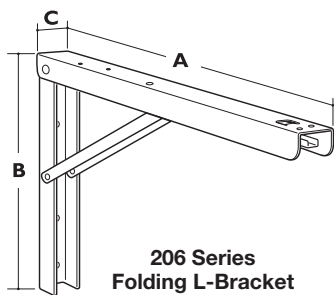

Dimensions				
Size	A	B	C	
12"	300mm	300mm	200mm	15mm
16"	400mm	400mm	270mm	20mm

1. PRODUCT NAME

206 Series Folding L-Brackets.
For heavy-duty storage and work surface applications when limitations and/or flexibility in space is critical.

2. MANUFACTURER

Knappe & Vogt Manufacturing Company
2700 Oak Industrial Dr. NE, Grand Rapids, MI USA 49505-6026
(616) 459-3311 | www.kv.com

3. PRODUCT DESCRIPTION

Basic Use: 206 Series Folding L-Brackets are manufactured for heavy-duty storage and work surface applications when limitations and/or flexibility in space is critical, such as retail stores, grocery stores, warehouses, industrial, repair garages, maintenance storage, business office storage, and residential storage. Mounts to most wall types.

Composition and Materials:

12" (300mm): 16 gauge cold rolled steel
16" (400mm): 14 gauge cold rolled steel

Sizes:

12" (300mm): (11.81") length x 200mm (7.87") height
16" (400mm): (15.75") length x 270mm (10.63") height
Width: 12" (300mm): 15mm (6.59"); 16" (400mm): 20mm (0.79")

Finishes: Zinc & White (powder-coat).

4. TECHNICAL DATA

Applicable Standards: Brackets are tested to meet or exceed ANSI performance standards as established by BHMA.

These load limits are intended to be used as general guidelines only, and no warranty — expressed or implied — is made by Knappe & Vogt.

Results were obtained by laboratory testing in accordance with ANSI/ BHMA A156.9-2003 performance standard. (Load ratings based on brackets being mounted on 16" centers. Wider spacing will result in reduced load capacity.) Actual use conditions will typically result in lower load capacity than laboratory conditions.

Representative testing in a fully configured application is the only way to assure proper performance, durability, and safety. Contact KV for verification testing service of your specific application.

Environmental Considerations:

Environment: Excessive humidity, salts, or other chemical agents can corrode the finish and attack metal or plastic components.

Fastening: Inadequate or incorrect fasteners can result in the bracket pulling loose and causing damage.

Alignment: Improper bracket alignment can result in a shelving system that is ineffective and unsafe.

5. INSTALLATION

For maximum loading capacity, brackets should be mounted directly to wall studs, which are generally found on 16" centers. Prior to drilling all holes, check to be sure that the bracket is vertically level.

Attach one bracket to wall stud by fastening one #10 x 2" screw through the top mounting hole in bracket. Use a level to position the second bracket at the same height as the first bracket and fasten it to a wall stud using one 2" screw through the top mounting hole.

Center the shelf on the brackets. Fasten a #8 screw through rear most mounting hole on each bracket. Confirm that the shelf folds properly and adjust position of brackets if necessary.

Finish securing the brackets to the wall by fastening #10 x 2" screws through the second top mounting hole and through one of two bottom mounting holes.

Finish securing the brackets to the shelf by fastening #8 screws through the second rear mounting hole and through one of two front mounting holes.

6. AVAILABILITY AND COST

Availability: Knappe & Vogt™ (KV) products are available from stocking distributors and through KV® Representatives worldwide.

Cost: Current pricing is available from area KV® Representatives. Please call for the nearest representative: (800) 253-1561.

7. WARRANTY

Limited Lifetime Warranty: Knappe & Vogt offers its standard Limited Lifetime Warranty to the initial purchaser of commercial products. This warranty covers defects in materials and workmanship which occur during normal use, and the remedy is limited to repair or replacement of defective products, at KV's option. Certain types of defects and damage are excluded from warranty coverage, costs and expenses are not covered, and additional restrictions apply. A copy of the Limited Lifetime Warranty, with all warranty details, limitations and disclaimers, is available on the Customer Care Connection location at www.kv.com or from KV Customer Service, 2700 Oak Industrial Drive, Grand Rapids, MI 49505, (800) 253-1561.

8. MAINTENANCE

206 Series Folding L-Brackets require no maintenance. Inspect for proper fit periodically and adjust when necessary. Replace as required or recommended by application.

9. TECHNICAL SERVICES

Knappe & Vogt™ and area representatives can assist with any application. For further information, or for the name of the representative nearest you, please call Knappe & Vogt™ Customer Service: (800) 253-1561 or visit our website at: www.kv.com.

10. FILING SYSTEMS

Additional product information, data sheets, application sheets, and a full catalog are available upon request from Knappe & Vogt™.

BHMA *Knappe & Vogt shelving products follow the ANSI testing standards established by BHMA.*

Knappe & Vogt reserves the right to change product specifications at any time without notice and without incurring responsibility for existing units. This information conforms to editorial style prescribed by The Construction Specifications Institute.