



OMNIA INDUSTRIES, INC.

CEDAR GROVE, NJ 07009



NOTE: Template may not be true-to-size. Please use for reference purposes only. DO NOT drill until measurements are verified.

FOR 1 3/4" DOOR

AUXILIARY DEADBOLT INSTALLATION TEMPLATE

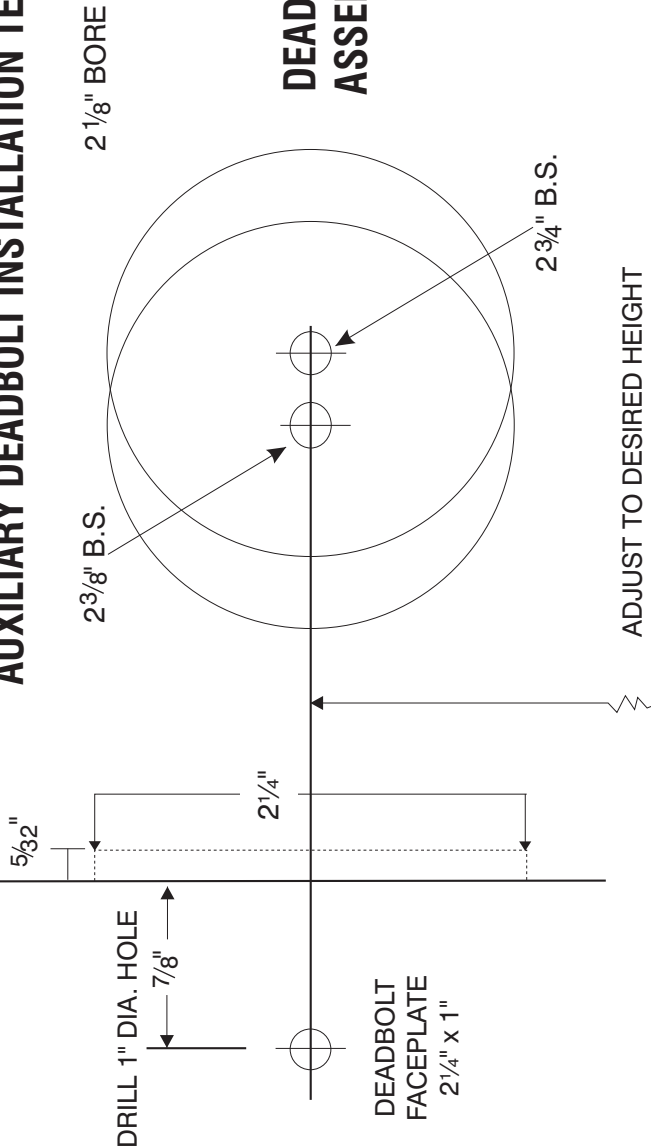

DEADBOLT ASSEMBLY

FOLD ALONG DOOR EDGE



OMNIA INDUSTRIES, INC.
CEDAR GROVE, NJ 07009



TOOLS NEEDED FOR INSTALLATION

- Drill • 1" Drill Bit • 2 1/8" Drill Bit
- Screwdriver • Chisel
- Allen Wrench (Supplied with Lock)

INSTALLATION INSTRUCTIONS

<p>1 MARK HOLES Using enclosed template, mark door as illustrated at desired lock height.</p> <p>Mark Center for 1" Hole Mark Center for 2 1/8" Hole</p>	<p>2 BORE TWO HOLES A. Bore 2 1/8" hole from one until point of drill breaks through. Then complete hole from other side. This prevents splintering. B. Bore 1" hole from edge of door. (See Template)</p> <p>Bore 2 1/8" Hole First Edge → Bore 1" Hole Second</p>	<p>3 MORTISE FOR FRONT Mortise (recess) for front 5/32" deep on edge of door. Deadbolt faceplate 2 1/4" x 1".</p> <p>Edge</p>
<p>4 A. Install cylinder housing assembly into large hole in door.</p> <p>Bolt Housing Cylinder Housing Top Arrow</p> <p>(2) Cyl. Housing Screws</p> <p>B. Insert bolt housing into 1" hole thru cylinder housing. C. Screw in (2) cylinder housing screws (1" long) into lower cylinder housing holes marked "A".</p>	<p>5 A. Assemble cylinder and O Ring into cylinder rose.</p> <p>Cylinder Rose O Ring Cylinder</p> <p>B. Insert key in cylinder. Pull key back One Notch. C. NOTE: Include cylinder ring for 1 3/8" thick doors ONLY.</p>	<p>6 A. Screw cylinder into housing until it stops. (Use key as wrench). B. Reverse rotation of cylinder at least one turn and until name is "Up".</p>
<p>7 A. Make sure cylinder lines up on door as shown.</p> <p>Allen Wrench</p> <p>B. Insert Allen wrench inside along side of bolt until it engages screw and tighten cylinder set screw.</p>	<p>8 A. Assemble front with screws. B. Insert tailpiece into hub with thumb turn in vertical position. C. Secure with machine screws provided.</p> <p>NOTE: If thumb turn binds grind end of tailpiece.</p>	<p>9 INSTALL REINFORCER, BOX AND STRIKE A. Shut door, turn key to extend bolt against jam. Bolt will leave an impression on the jam for strike location.</p> <p>Reinforcer Strike Box</p> <p>B. Drill 1" dia. hole thru jam. C. Mortise out for reinforcer & box. D. Drill (2) 9/32" dia. holes thru jam only for (2) 3" long screws.</p>

CAUTION: DOOR AND FRAME MANUFACTURERS

When door gasketing or silencers are used, proper allowances must be made for strike location to maintain a common centerline with lock and door so that the bolt will freely enter strike.

OM-ADBTI

Rev. 12/29/10

AUXILIARY DEADBOLT — Exploded View

Shown as "A" Function

- A — Key
- B — Cylinder
- C — Cam
- D — "O" Ring
- E — Rose
- F — Housing
- G — Rose Screws
- H — Turnpiece
Rose Assembly
- I — Tailpiece
- J — Housing Screws
- K — Cylinder Set
Screws
- L — Faceplate
- M — Screws
- N — Deadbolt

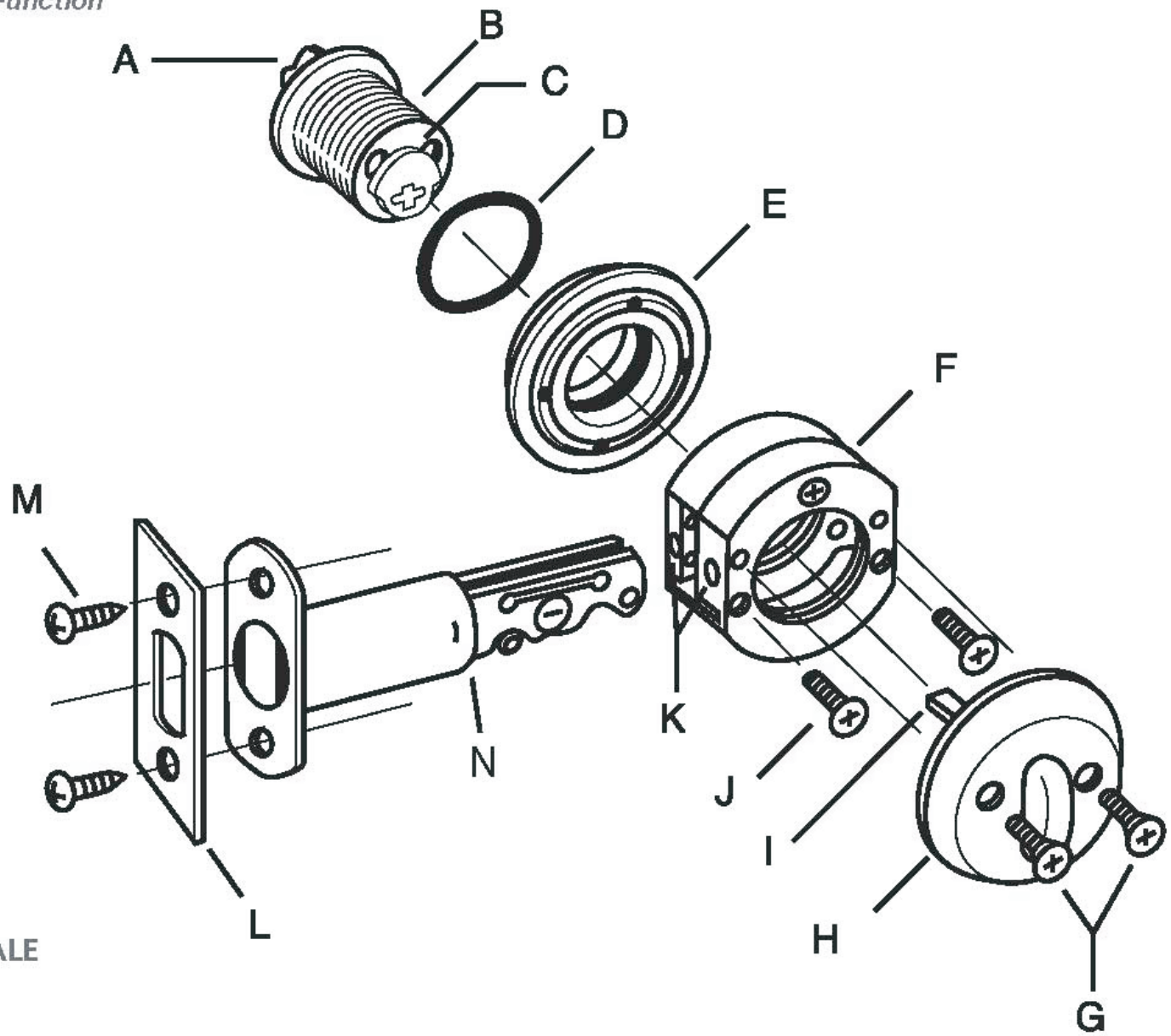

DRAWINGS NOT TO SCALE