

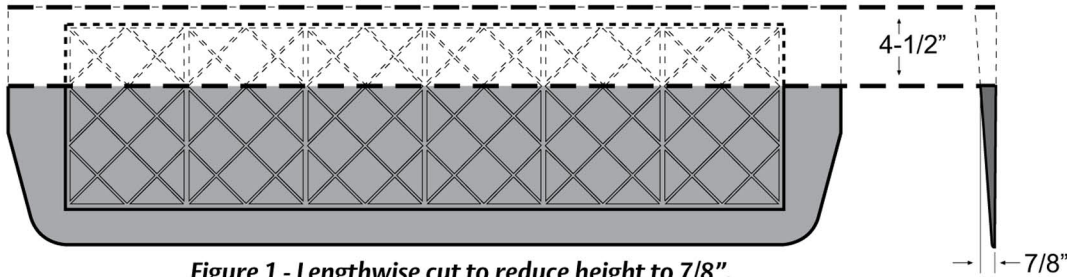

**WARNING! DO NOT ATTEMPT TO CUT THIS MATERIAL WITH ROTATING SAW BLADES OF ANY TYPE, INCLUDING HAND CIRCULAR SAWS AND MACHINE TOOLS. THEY CAN GRAB THE MATERIAL CAUSING SUDDEN KICKBACKS OR JAMS WHICH MAY CAUSE SERIOUS INJURY.**

## **INSTALLATION INSTRUCTIONS:**

1. Prior to adhesive attachment, the PEMKO Recycled Rubber Ramp™ should be coped, trimmed, and/or planed as required.
2. If the ramp is too tall, it can be reduced in height to obtain the desired offset height. The glue grooves in the bottom can also serve as cutting guides. (See Figure 1 below with typical height cut-downs).



**Figure 1 - Lengthwise cut to reduce height to 7/8".**

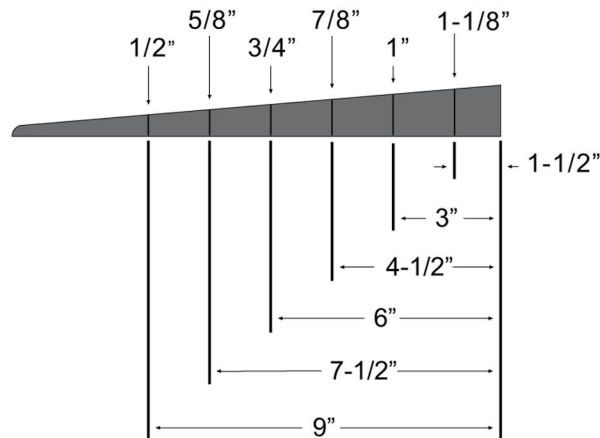

3. Figure 2: Coping to fit is easily accomplished with a hand saw or power jigsaw.

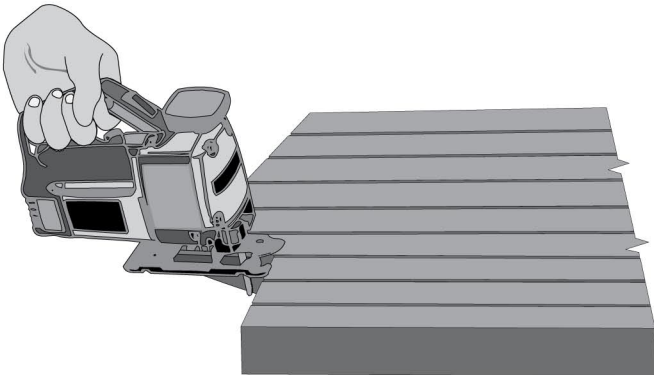

**Figure 2**

4. When the fitting is complete, the ramp is ready to be bonded in place with adhesive. PEMKO strongly recommends using RR200 Adhesive. Recommended quantity of adhesive is one 9.8 oz. cartridge for each 7 sq. feet of ramp.

**Important Note: Do not apply weight or walk on ramp for 24 hours, allowing adhesive to fully cure.**