

CUSTOMER DRAWING

This drawing is the property of Rev-A-Shelf (RAS) and is disclosed in confidence to the extent its subject matter is original to RAS. Any vendor receiving this drawing from RAS shall hold and use this drawing for the sole benefit of RAS and shall not disclose it to, or use or reproduce it for any third party, or perform any act adverse to the interest of RAS with respect to this drawing without the express written permission of RAS. Vendors shall not revise any physical, dimensional or performance characteristic unless authorized by Rev-A-Shelf Engineering.

REV.	DATE	BY	DESCRIPTION OF CHANGE

INCH [MM]	AMERICAN PROJECTION 	DRAWN	BY	DATE	REV-A-SHELF, INC.	
		SIZE B		53WC DOUBLE 27QT		
TOLERANCES MAT. DEC. (WOOD) .XX .03 [.8mm] (OTHER) .XX .02 [.5mm] (ALL) .XXX .005 [.13mm] FRACTIONS 1/32 [.8mm]		ANGLES 1/2±	MATERIAL	DRAWING NO. 53WC-1527SCDM-2XX	SCALE	
		FINISH	PART NO. 53WC-1527SCDM-2XX	SHEET 1 OF 2		

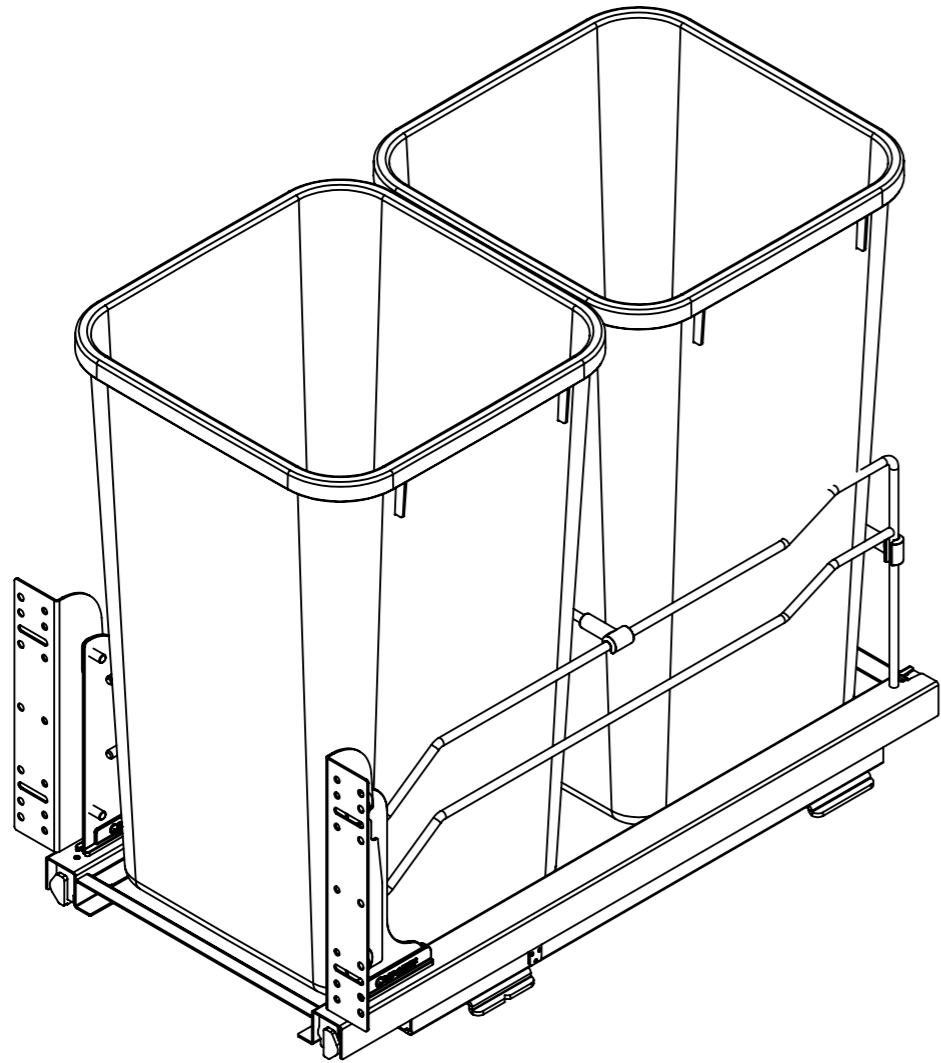

PART DIMENSIONS		
	MIN	MAX
WIDTH	11.01	
DEPTH	22.09	
HEIGHT	18.94	
WEIGHT		
DIAMETER		
RADIUS		
CONTAINER CAPACITY	(2) 27 QT	
CONTAINER UOM	POLYPROPYLENE	

MIN CABINET OPENING	
WIDTH	11,125
DEPTH	22,125
HEIGHT	20,00

PRODUCT MAX WEIGHT RATING
90LBS

SLIDE SPECIFICATIONS				
SLIDE TYPE	UNDERMOUNT	SLIDE EXTENSION	FULL	MAX WEIGHT RATING
SLIDE CLOSING	SOFT/SELF	SLIDE LENGTH	560MM	
SLIDE MOUNTING	BOTTOM	SLIDE FINISH	ZINC	90LBS

CUSTOMER DRAWING

This drawing is the property of Rev-A-Shelf (RAS) and is disclosed in confidence to the extent its subject matter is original to RAS. Any vendor receiving this drawing from RAS shall hold and use this drawing for the sole benefit of RAS and shall not disclose it to, or use or reproduce it for any third party, or perform any act adverse to the interest of RAS with respect to this drawing without the express written permission of RAS. Vendors shall not revise any physical, dimensional or performance characteristic unless authorized by Rev-A-Shelf Engineering.

REV.	DATE	BY	DESCRIPTION OF CHANGE

INCH [MM]	AMERICAN PROJECTION	DRAWN	BY	DATE	REV-A-SHELF, INC.	
					SIZE B 53WC DOUBLE 27QT	
TOLERANCES		ANGLES 1/2±	MATERIAL	DRAWING NO. 53WC-1527SCDM-2XX		SCALE
MAT. (WOOD) .XX .03 [.8mm]	DEC. (OTHER) .XX .02 [.5mm]		FINISH	PART NO. 53WC-1527SCDM-2XX	SHEET 2 OF 2	
[ALL] .XXX .005 [.13 mm]						
FRACTIONS 1/32 [.8 mm]						