

# RAS-ML-HDCR SERIES

# HEAVY-DUTY MIXER LIFT

Typical Cabinet PRODUCT DIMENSIONS

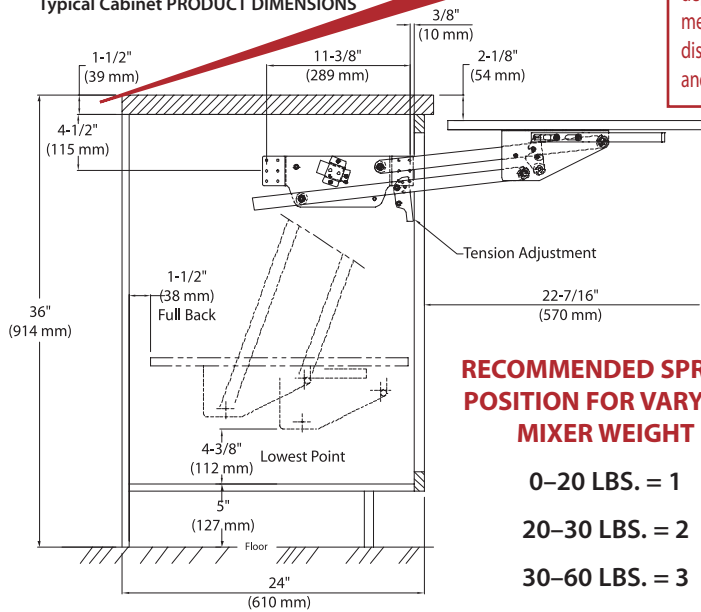

NOTE: The dimensions listed provide clearance for an item 15<sup>3</sup>/<sub>16</sub>" H x 14<sup>1</sup>/<sub>16</sub>" D placed at the front edge of the shelf. Depending on your cabinet construction and your specific height and depth requirements, the 4<sup>1</sup>/<sub>2</sub>" dimension from the top of the cabinet to the middle of the lifting mechanism can be reduced to allow the platform to be closer to counter height, thus a greater distance below the unit in the closed position. It can also be increased to allow for items taller and deeper than the dimensions provided.

### RECOMMENDED SPRING POSITION FOR VARYING MIXER WEIGHT

- 0-20 LBS. = 1
- 20-30 LBS. = 2
- 30-60 LBS. = 3

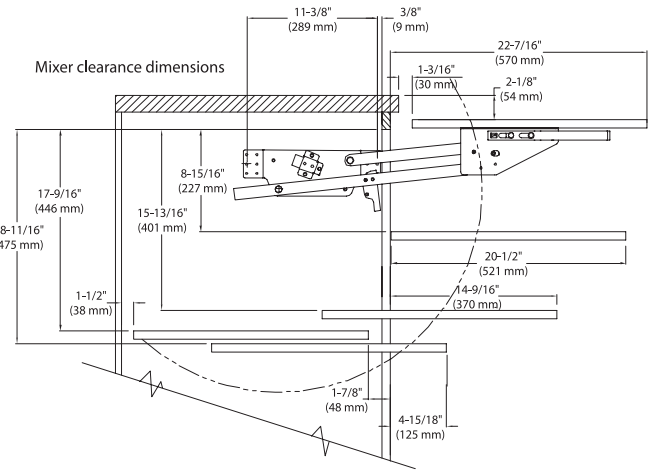

### SHELF NOT INCLUDED

To determine shelf size measure the distance between mounting plates when installed minus 1/4". Recommended length of shelf is 20 1/2".

