

FOLDING BRACKET (W/STOPPER)

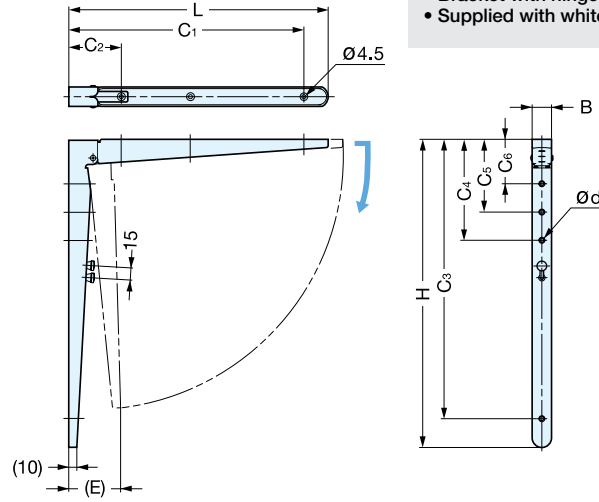

BTO



- Folding bracket with manual lock lever.
- Slide the lock lever to lock/unlock in open position.
- Bracket with hinge function in one unit.
- Supplied with white painted screws.

Item No.	L	H	B	(E)	C ₁	C ₂	C ₃	C ₄	C ₅	C ₆	d	t
BTO-300S	241 (9-31/64")	300 (11-13/16")	23 (29/32")	(57)	211	61	270	80	50	-	5	-
BTO-300W												

Item No.	Load Capacity (kg)	Weight (g)	Box (pcs)	Carton (pcs)	NO.	Part Name	Material	Finish/Color
BTO-300S	40.8 (89.9 lbs)/pc	510	10	40	①	Body	304 Stainless Steel (S)/Steel (W)	Satin (S)/White (W)
BTO-300W					②	Knob	Brass	Plain

FOLDING BRACKET (W/STOPPER)



BOS

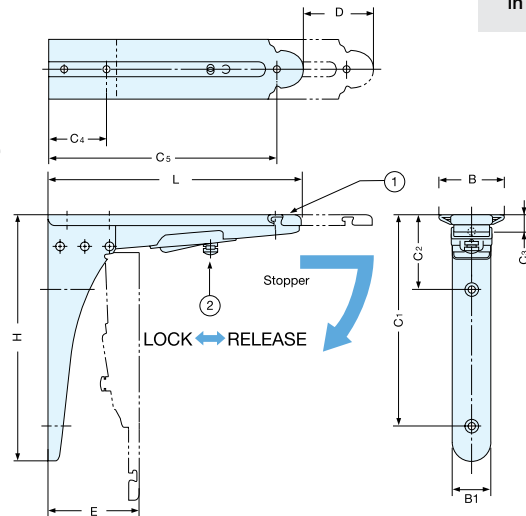

- Folding bracket with locking bracket.
- Slide the locking bracket to lock/unlock in open position.

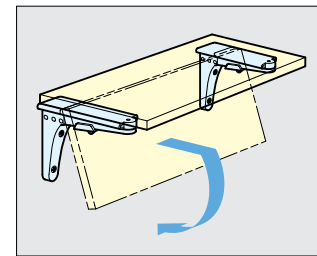

NO.	Part Name	Material	Finish/Color
①	Body	304 Stainless Steel	Satin
②	Knob	Brass	Nickel
	Cap	EPDM	Black

Item No.	L	H	B	B1	D	E	C ₁	C ₂	C ₃	C ₄	C ₅	Load Capacity (kg)/pc	Weight (g)	Box (pcs)	Carton (pcs)
BOS-180	181 (7-1/8")	181 (7-1/8")	45.5 (1-51/64")	26	50	65	155	56	11.5	42	162	40 (88 lbs)	476	1	20
BOS-240	240 (9-7/16")	250 (9-27/32")			64	81	220	70	15	80	215	33 (72 lbs)	770		