

## Models:

Pocket® Light 1W . . . . . P/N: POC-LED-M  
Pocket® Light 3W . . . . . P/N: POC-3LEDSFR-M  
DC Transformer 18W . . . . P/N: DC-ELT18-CON  
DC Transformer 60W . . . . P/N: DC-ELT60-CON

## Accessories:

Extension Cord D . . . . . P/N: LED-LINKD  
Others: Touch On/Off Switch, Round Switch, Roll Switch, Magnet Switch, Remote Control LED Dimmer, Manual Rotary Dimmer, Hole Saw & Mandrel Kit, 1W Replacement LED Chips.

# Installation Instructions

## Pocket® LED Lights - 12VDC

### 1W and 3W

## READ ALL INSTRUCTIONS BEFORE INSTALLING SYSTEM.

Before beginning installation, be sure power is turned OFF to light system.

Note: 18W DC Transformer can supply power to a maximum of (18) 1W Pockits® or (6) 3W Pockits®. 60W DC Transformer can supply power to a maximum of (60) 1W Pockits® or (20) 3W Pockits®.

- FIRST, roughly lay out lighting system before installation to help verify final positioning of all components. Check that Power Cord will properly reach 120V power source.
- Install the DC Transformer and Mounting Block, but do not plug Power Cord into 120V power source yet.

Next, select either surface mount or recess mount options.

## Steps to surface mount:

Note: First determine whether Pocket® wires will ...

- (a) pass through a 5mm (3/16") hole in mounting surface (shelf, etc.) or
- (b) pass through knockout in Mounting Ring and run along surface. Select best method.

1. Determine final location of light(s). Mark exact position of light fixture on surface using Mounting Ring as a template. Mark for (2) screw holes.  
Note: If you decide to route wires through hole in surface, mark placement of 5mm (3/16") hole *inside* the perimeter of Mounting Ring, so wires will be hidden when Ring is mounted.
2. Drill 1.5mm (1/16") pilot holes for the mounting screws (provided). If needed, drill 5mm (3/16") in mounting surface for wire hole. Be sure to remove rough areas at edge and inside hole.
3. Pass the light fixture wires through Mounting Ring. Then properly route wire either through hole in mounting surface or Mounting Ring knockout (see #1). Attach Mounting Ring to surface with (2) screws.
4. Push Pocket® Light Body into Mounting Ring allowing metal spring tabs on Light Body to hold in final position (see #2). See Final Steps below.

## Steps to recess mount:

1. Determine final location of light(s).
2. Drill 54mm (2-1/8") hole for 1W light, or 57mm (2-1/4") hole for 3W light, to recess mount Pocket® Light Body.† Be sure to remove rough areas at edge and inside hole (see #3).
3. Feed wires through hole and push Pocket® into place, allowing metal spring tabs on Light Body to hold in position. See Final Steps.

## Final Steps:

- Complete wiring installation to Mounting Block. Push needle ends of Pocket® wires into AMP® connector until they are completely seated.  
**IMPORTANT:** Make sure you match polarity (+) and (-) of the wires to the AMP® connector. See markings on wires and connector (see #4).
- Snap AMP® connector into Mounting Block (see #5). Then plug Transformer into 120V power supply (see #6).

**Extension Cords for lights:** Extension Cord Ds are used when light fixtures are installed farther apart than the standard cord lengths will allow. Extension Cord Ds are available in 15cm (6"), 25cm (10"), 60cm (24"), 120cm (48"), or 180cm (72"), lengths. Note: Maximum length of cord from transformer to light should be 5m (16'). Longer cords could result in poor light quality.

† When drilling holes for recess mounting of Pocket® Light Body, order Tresco® Hole Saw (P/N: DBSC54 for 54mm hole, or DBSC57 for 57mm hole), and Mandrel Bit (P/N: DBSC3).

NOTICE: THIS PRODUCT MUST BE INSTALLED IN ACCORDANCE WITH THE APPLICABLE INSTALLATION CODE BY A PERSON FAMILIAR WITH THE CONSTRUCTION AND OPERATION OF THE PRODUCT AND THE HAZARDS INVOLVED. CONSULT A QUALIFIED ELECTRICIAN TO ENSURE CORRECT BRANCH CIRCUIT CONDUCTOR.

CE PRODUIT DOIT ETRE INSTALLE SELON LE CODE D'INSTALLATION PERTINENT, PAR UNE PERSONNE QUI CONNAIT BIEN LE PRODUIT ET SON FONCTIONNEMENT AINSI QUE LES RISQUES INHERENTS. ATTENTION-RISQUE D'INCENDIE. CONSULTER UN ELECTRICIEN QUALIFIE POUR VOUS ASSURER QUE LES CONDUCTEURS DE LA DERIVATION SONT ADEQUATS.

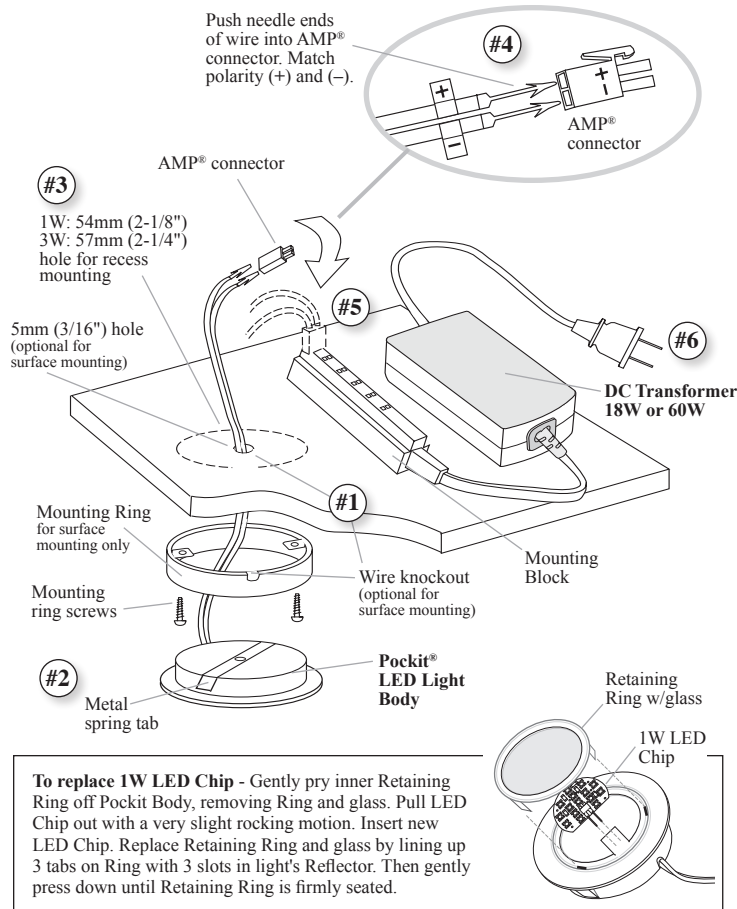

**To replace 1W LED Chip** - Gently pry inner Retaining Ring off Pocket Body, removing Ring and glass. Pull LED Chip out with a very slight rocking motion. Insert new LED Chip. Replace Retaining Ring and glass by lining up 3 tabs on Ring with 3 slots in light's Reflector. Then gently press down until Retaining Ring is firmly seated.

## IMPORTANT SAFETY INSTRUCTIONS

CAUTION: To reduce the risk of fire, electric shock, exposure to excessive UV radiation or injury to persons:

- LED Chip can only be replaced on the 1W Pocket® LED system. Use only 1W replacement LED Chips (Tresco® P/N LB-LED-XDSK). Note: 3W LED Chips are not replaceable.
- LED lights are bright. Do not look directly at light.
- Not intended to be used in damp locations or outdoor areas.
- Not intended for recessed installation in ceilings or soffits.
- Do not conceal 120V Power Supply Cord or power supply inside a wall, ceiling, soffit, or similar permanent structure. For concealing, please consult a licensed electrician.

This light is intended to be used as a cabinet light on wood, particle board or other structurally sound, heat resistant surface. Care should be taken during and after installation to avoid contact of light with wiring, cord, or any combustible material.



**Tresco International Ltd. Co.**  
801 E. Middletown Rd.  
North Lima, Ohio USA 44452



Intertek

PocLEDln/1110/grx

**Tel: 800-227-1171**  
**Fax: 800-841-2523**  
**Tel: 330-549-2230**  
**Fax: 330-549-2260**

**Email: custsvc@trescointl.com**  
**www.trescointernational.com**